

WELCAREO

PUREAIR

MODEL: WPA300



HOUSEHOLD AIR PURIFIER

Instruction Manual & Warranty Information



Read Instructions Carefully Before Use

WELCARE

PUREAIR

Thank you for purchasing this Welcare PureAir *Household Air Purifier*

Model: WPA300



Please keep this instruction manual in a safe place where it is readily available.

Note: *The illustrations in this manual may differ slightly from the product itself.*

Contents

Important Safety Information	4
Features	5
Air Quality Indicator	5
Box Contents	6
Welcare PureAir Household Air Purifier Components	6
Welcare PureAir Household Air Purifier Display	7
Filters and Functions	7
Before Using the Air Purifier.	9
Air Purifier Filter Installation	10
Replacement Accessories	11
Using the Air Purifier	11
Filter Replacement	12
Cleaning and Maintenance	13
Air Quality Sensor.	14
Cleaning the Pre-Filter (ONLY)	14
Storage.	14
Troubleshooting	15
Warranty Information	16
Warranty Form	17
Technical Data	19
Disposal	20

Important Safety Information



Read this section thoroughly before using the product.

Please ensure you observe the safety instructions to avoid accidents, injury and damage.

Intended purpose

The Welcare PureAir Household Air Purifier removes contaminants from the air in a room to improve indoor air quality. Indoor air pollution comes mainly from pollen, dust, harmful gasses including smoke, body odour and other substances which can be a serious problem, causing dizziness, drowsiness, congestion, and nausea. Clean, pure air is important to a person's health and wellbeing.

This product is **NOT** a therapeutic device.

This product is not intended for use by persons (including children) with limited physical, sensory, or mental abilities or lacking experience and/or knowledge, unless they are supervised by a person responsible for their safety or have received and understand the instructions/safety warnings for use of the product from this person in advance.

Safety Warnings

- Keep the product and its components out of reach of children.
- Keep children away from the packaging material.
- Dispose of the plastic bag. Keep away from babies and children to avoid suffocation.
- **DO NOT** let children play with the product.

Warnings

- **DO NOT** drop or put heavy objects on the product.
- **DO NOT** allow the product to come into contact with any sharp objects, as this could cause damage to the product.
- **DO NOT** attempt to open or disassemble the product.
- **DO NOT** expose to temperatures over 55°C.
- Only use in a 220-240V wall outlet to avoid overheating.
- If the supplied power cord is damaged, it must be replaced by the manufacturer, its service agent, or a similarly qualified person to avoid a hazard.
- Clean the product with a damp soft cloth and mild detergent if required. **DO NOT** use any harsh chemical cleaning agents. Dry with a soft cloth.
- Never use liquids such as water, detergents, or flammable solvents to clean the product.
- When cleaning the product, please disconnect from the power source.
- This product uses precision components. Position the product on an even, steady surface to prevent it from falling or being damaged.
- The product should **NOT** be used for inside the kitchen or other areas where heavy fat particles are present.

Important Safety Information - *continued*





- The product should **NOT** be used for ventilation or extraction purposes.
- Keep away from any wet areas.
- Keep away from any combustible material.
- Always keep the product at least 1 metre away from the television or radio when in use.
- **DO NOT** plug the power plug in the same power socket as the television or radio.
- Keep the space surrounding the product unobstructed, ensuring 50cm clearance on both sides of the air inlet and outlet and 10cm from the back of the product.
- **DO NOT** cover the air inlet and outlet.

Features

- 6 Point HEPA (H13) Air Purification System
- Suitable for large areas up to 40~50 m² (average size living room 25m²)
- Filters dust, pollen, smoke, germs, and bacteria
- Removes odours
- Touch panel display for easy operation
- Adjustable fan speed - 4 Levels (one button)
- Timing function 1hr - 4hr - 8hr
- Filter replacement reminder display
- Silent mode
- Night mode
- Low- noise operation
- Dust sensor & Air quality indicator (4 colours):
Blue-Perfect, **Green**-Good, **Purple**-Normal, **Red**-Bad

Air Quality Indicator

The air quality indicator reflects the air quality conditions of the room.

	Blue	(PM2.5=0~50)	PERFECT
	Green	(PM2.5=50~100)	GOOD
	Purple	(PM2.5=100~150)	NORMAL
	Red	(PM2.5=>150)	BAD

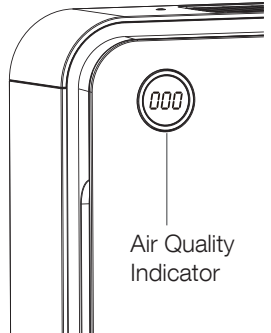

PM2.5 = particles which have a diameter of less than 2.5 microns

Box Contents

1 x Air purifier (including 6 Point HEPA (H13) Air Purification System inside)

1 x Instruction Manual & Warranty Information

Welcare PureAir Household Air Purifier Components

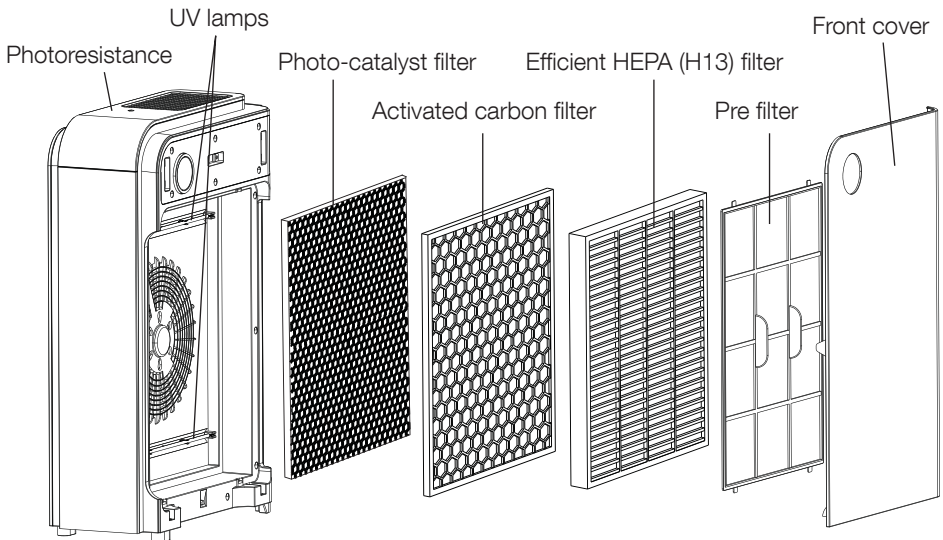
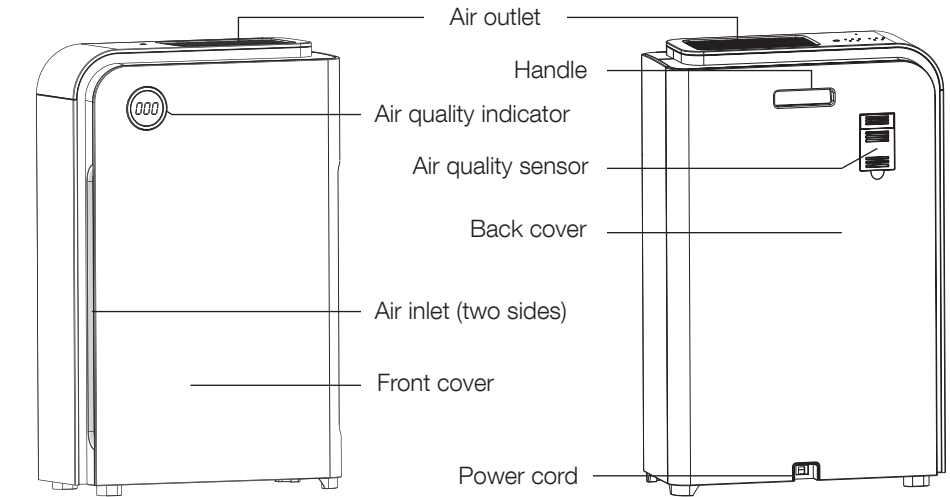

Welcare PureAir Household Air Purifier Display

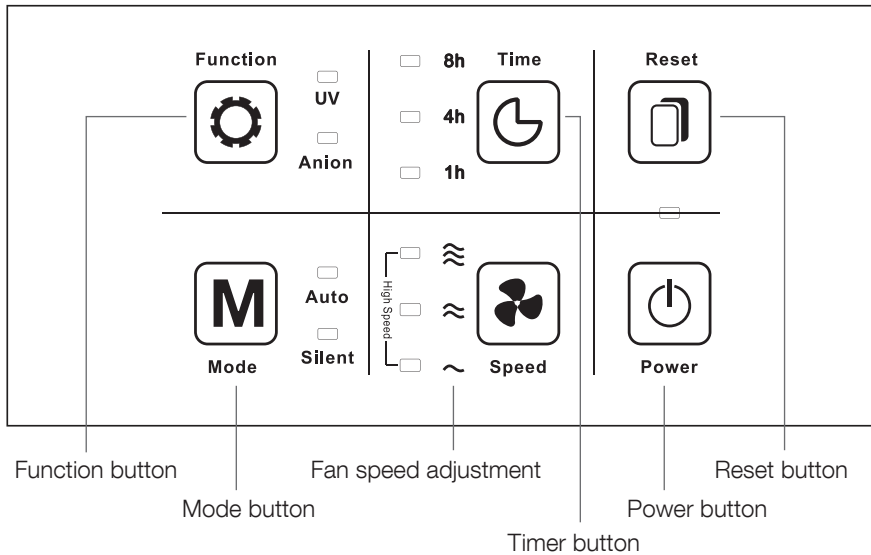

Filters and Functions

The 6 Point Air Purification System effectively purifies the air, providing a healthy living environment.

1. Pre-Filter
2. Efficient HEPA (H13) Filter
3. Activated Carbon Filter
4. Photocatalyst Filter
5. Ionizer (Anion generator)
6. 2 pcs UV Lights

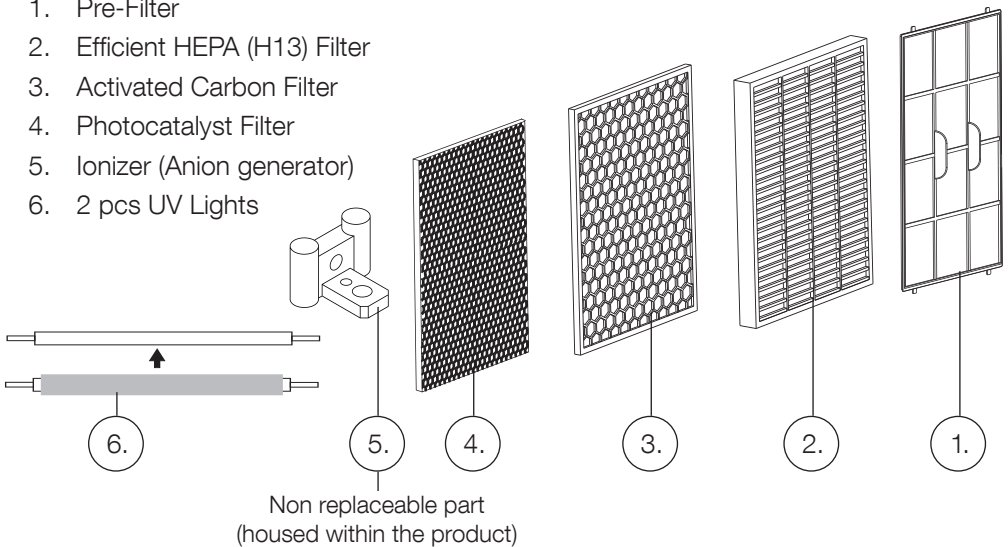

Filters and Functions - *continued*

1. **Pre-Filter**

Uses a micron mesh filter, which blocks 2.5mm particle matter > 99.9%. Air can be cleaned effectively, preventing contaminants such as dirt, hair, pet fur, dander, and coarse dust from entering the air purifier. The Pre-Filter protects all the filters and prolongs their life.

2. **Efficient HEPA (H13) Filter**

The rate of removing 99.9% of minor particles as small as 0.3 microns in diameter from the air, preventing the spread of allergens and bacteria such as pollen, smog, and germs.

3. **Activated Carbon Filter**

Used to remove common household contaminants such as odours, second-hand smoke, and gas pollutants.

4. **Photocatalyst Filter**

Uses ultraviolet light to remove chemicals such as formaldehyde, toluene, xylene, ammonia, TVOC and other pollutants.









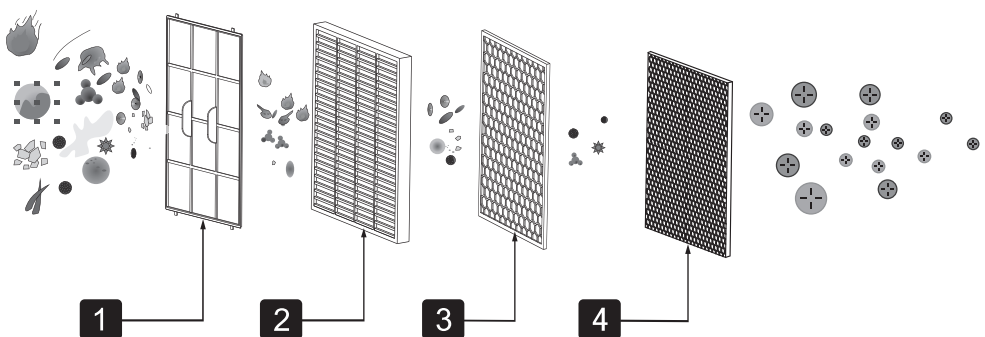

5. **Ionizer (Anion Generator)**







Produces large amounts of negative ions (or anions) to remove airborne pollutants from the air, eliminating odours with strong absorption. The negative ions (or anions) will make bacteria lose their activity, rendering them harmless.

6. **UV Lights**

Combined with photocatalyst filter, UV light creates highly effective sterilisation which kills a variety of common bacteria and germs.



The allergens						
 Coarse dust	 Hair	 Harmful particles	 Dander	 Dust	 Pollen	 Pet fur
 Smoke	 Dust mites	 Odour	 Chemical substances			

Bacteria					
 Yeast	 Mycotic spore	 Germs	 Mildew	 Mould	 Bacteria

Note: 500v cold cathode UV lamp can be used safely and will not produce Ozone.

Before Using the Air Purifier

- Before turning on the product for the first time, remove the filter bags.
- Carefully remove all packaging materials and keep the enclosed documents in a safe place.
- **Keep the packaging, product, and its components out of reach of children.**
- Check the product is intact. **DO NOT** use if broken.
- Before the initial use of the product, please install the filters correctly as per instructions.

If any abnormalities are detected, please contact our service centre:

In Australia - 1800 807 464

In New Zealand - 0800 523 583

Air Purifier Filter Installation

1. Gently hold onto the groove of both side of the front panel, gently pulling outwards to remove.
2. Remove the filters and UV lamps from the air purifier.
3. Remove all the packaging from the filters and UV lamps and place the Air Purifier on a dry, stable, horizontal position.

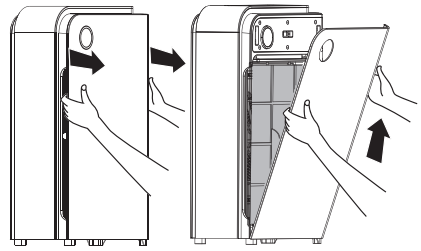

Dispose of the plastic bag. **Keep away from babies and children to avoid suffocation.**

4. Place the UV lamps into the Air Purifier by holding each end of the UV lamp, gently placing each of the needles into the metal slot inside the product. Repeat with the second UV lamp. Initial lamps will be factory fitter.

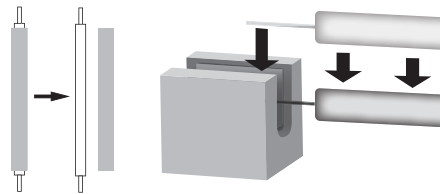

5. Place each of the filters back inside the air purifier in the order indicated below, ensuring the labels on the filters are facing outwards.

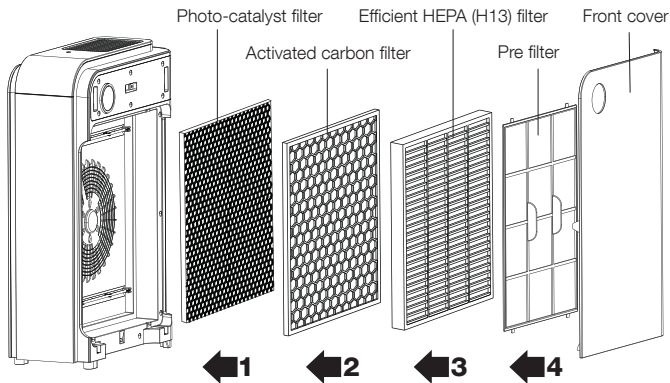

6. Reinstall the front panel by aligning and inserting bottom clips into the fixed grooves on the base of the product and gently push to shut. (*right*)

- The efficient HEPA (H13) Filter and Activated Carbon Filter must be replaced every 12 months
- The Photocatalyst Filter must be replaced every 3 years

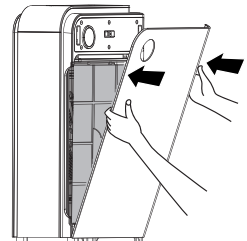

Note Do not operate the air purifier without the filters or UV lamps securely reinstalled.

Replacement Accessories

Replacement accessories can be purchased online or by contacting us directly:

Australia: 1800 807 464 www.welcare.com.au

New Zealand: 0800 523 583 www.jadavey.co.nz

Part Code	Part Name
WPA300-1	Pre-Filter (FIL3001-PRE)
WPA300-4	Photocatalyst Filter (FIL3001PH)
WPA300-5	UV Lights 2pcs (AP3001SP-UV)
WPA300-6	HEPA (H13) & Carbon Filter (FIL3001-RF)

Using the Air Purifier

Standby:



Insert the plug of Air Purifier into power source. The buzzer will ring, and all the indicators will light up and flash twice detecting the air quality automatically. All indicators will then stop flashing leaving the Air Purifier in **Standby Mode** and the **RED** indicator illuminated.

Power On/Off:



Tap the **Power** icon to switch the air purifier **ON** defaulting to **Auto Mode**. The **BLUE** indicator light will illuminate.

Tap again to switch the power **OFF** leaving the Air Purifier in **Standby Mode**. The **RED** indicator light will illuminate.

Mode:



Mode

Auto **Auto Mode:** When selecting the **Auto Mode**, the **Air Quality Indicator** illuminates, slowly flashing **BLUE**, **RED**, **PURPLE**, **GREEN** and **Fan Speed 2** illuminates for 30 seconds while detecting the air quality of the room. The **Auto Mode** will select the most appropriate fan speed required.

Silent Mode: Tap the **Mode** icon to choose **Silent Mode**. The fan speed will change to level 1 operating at a low noise level.

Night Mode: A built-in radial sensor will sense the strength of the light in the room automatically. If the room is dark, all lights of the Air Purifier will be dimmed and will change to **Silent Mode**.

Using the Air Purifier - *continued*

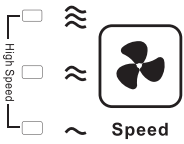

Speed:

Tap the fan **Speed** icon 1,2,3 or 4 times to adjust the air flow. The **BLUE** indicator light will illuminate:

One	Two	Three	Four
<input type="checkbox"/> ≡	<input type="checkbox"/> ≡	<input checked="" type="checkbox"/> ≡	<input checked="" type="checkbox"/> ≡
<input type="checkbox"/> ≈	<input checked="" type="checkbox"/> ≈	<input type="checkbox"/> ≈	<input checked="" type="checkbox"/> ≈
<input checked="" type="checkbox"/> ~	<input type="checkbox"/> ~	<input type="checkbox"/> ~	<input checked="" type="checkbox"/> ~

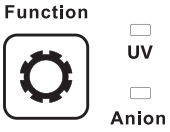

Function:

Anion: Tap the **Function** icon once to choose the **Anion** function. The **BLUE** indicator light will illuminate **Anion**.

UV: Tap the **Function** icon again to choose the **UV** (Ultraviolet Light) function. The **BLUE** indicator light will illuminate **UV**.

Tap the **Function** icon a third time to choose both the **Anion** and **UV** function. The **BLUE** indicator light will illuminate **Anion** and **UV**.

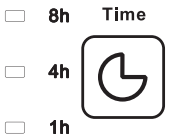

Time:

Tap the **Time** icon 1,2,3 or 4 times to adjust timer.

The **BLUE** indicator light will illuminate:

1H	4H	8H
<input type="checkbox"/> 8h	<input type="checkbox"/> 8h	<input checked="" type="checkbox"/> 8h
<input type="checkbox"/> 4h	<input checked="" type="checkbox"/> 4h	<input type="checkbox"/> 4h
<input checked="" type="checkbox"/> 1h	<input type="checkbox"/> 1h	<input type="checkbox"/> 1h

Note: *If no timer is set, the air purifier will continuously operate until it is manually switched off.*



Reset:

Air Quality Indicator: Tap the **Reset** icon to turn **Air Quality** indicator **ON/OFF**.

Reset Filter: After replacing the air filter, tap the Reset button for at least 5 seconds.

Note: *This function is available after the replacement of the filters.*

Filter Replacement

- The **Reset Button** illuminates and flashes slowly (**RED** when in **Standby** Mode and **BLUE** when the unit is working) as a reminder to replace the 2 filters (HEPA 13 Filter and Activated Carbon Filter). These filters will need replacing after approximately 1600 hours of use or up to 1 year.
- The **Photo-Catalyst Filter** needs replacing once every 3 years **ONLY**, or after approximately 2,000 hours of use, (based on an average use of 8 hours a day - 7 days a week) or if exposed to direct sunlight for more than 2 hours.

Filter Replacement - *continued*

Note: the air purifier will still work when the **Reset Button** indicator light is flashing.

- Turn off the power from the product and unplug from the power source before replacing the filters.
- Remove all packing from each of the new filters and dispose of as per instructions.
- Place the filters into the product in the correct order (refer page 10).
- Align and insert the bottom clips into the hollows at the base of the product and gently push to shut.
- After replacing the air filters, insert the plug back into the power source.
- Press the **Reset Mode** and hold for 5 seconds. The air purifier will then reset.

To ensure a healthy environment, the filters should always be changed when the product indicates.

Cleaning and Maintenance

- When cleaning, always turn off the power and disconnect from the power source.
- Clean the outside of the product with a damp cloth and mild detergent regularly to prevent dust to accumulate on the product.
- Use a soft dry cloth to clean the inlet and outlet.
- **DO NOT** put the product in water or any other liquids.
- **DO NOT** use any harsh chemical cleaning agents including bleach or alcohol.
- If the product is being used in an extremely dusty environment, clean more regularly.
- **ONLY** the **Pre-Filter** can be cleaned with water. See following instructions. The other filters **CANNOT** be cleaned.

Air Quality Sensor

1. Use a soft brush to clean the protective cover of inlet/outlet of the Air Quality Sensor.
2. Remove the protective cover of the Air Quality Sensor.
3. Use a damp cotton bud to clean inlet/outlet of the Air Quality Sensor.
4. Dry inlet/outlet of the Air Quality Sensor with a dry cotton bud.
5. Replace the protective cover.

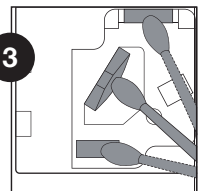
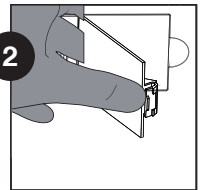
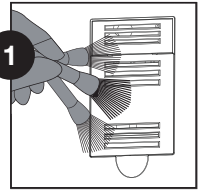

Cleaning the Pre-Filter (ONLY)

- Gently hold onto the groove of both side of the front panel, gently pull outwards to remove.
- Remove the Pre-Filter from the product.
- Use a soft-clean brush or a low powered vacuum cleaner to remove any particles.
- Use water and mild detergent to clean thoroughly.
- Let dry completely and then place back inside product, securely clicking into place.
- Place the front panel back on the product as per instructions (page 10).

Storage

- Wipe away any dirt and dust from the product.
- Store in a safe cool dry place, away from children as per Safety Warnings.
- Ensure the product is always stored in an upright position.
- **DO NOT** place any heavy objects on the product.
- If the product is not going to be used for a long period, turn off and unplug from the power source.

Troubleshooting

Problem	Possible Cause	Solution
The Air Purifier does not turn on.	The machine plug and power plug are not inserted into the power source correctly.	Insert into the power source correctly.
	The front panel may not be installed securely.	Reinstall the front panel.
	The power plug may be damaged.	Contact our customer service centre.
The fan does not work.	The product inlet or outlet may be blocked.	Remove any objects away from the inlet/outlet area.
	Plastic packaging may not have been removed.	Remove any plastic packaging from the filter.
	The product had been put on an uneven surface.	Place the product on an even, stable surface.
	Loose or foreign particles inside the product.	Contact our customer service centre.
Performance is poor or is not performing at its optimal purification performance.	The area around the product is not clear of objects.	Remove any objects around the product.
	Filters may need replacing.	Replace the filter as per instructions.
	Washable Pre-Filter may be dirty.	Wash Pre-filter as per instructions.
	Not enough space around the product.	Ensure the product has at least 50cm clearance on both sides of the air inlet and the outlet and at least 10cm clearance on the back of the product.
	The filters have not been installed or installed correctly.	Ensure the filter are installed as per instructions.
	Exceeding the expected coverage area.	Ensure the product is in a suitable sized room.

If the problem is not solved by the troubleshooting guide or you have any queries, please contact our service centre:

In Australia - 1800 807 464

In New Zealand - 0800 523 583

DO NOT attempt to open or repair the product yourself.

Warranty Information

PRODUCT WARRANTY

Please register your warranty information at: **AUS - www.welcare.com.au**
NZ - www.jadavey.co.nz

This Welcare PureAir product is warranted to be free of manufacturing defects for 1 year from the date of purchase*. This warranty is void if the product is modified or altered, is subject to misuse or abuse, damaged in transit or lack of responsible care, is dropped, if damage occurs by reason of failure to follow the written instruction booklet, or if product repairs are carried out without authority from J.A. Davey Pty Ltd.

We will repair, or at our option replace free of charge, any parts necessary to correct material or workmanship, or replace the entire product and return to you during the period of the warranty. Otherwise, we will quote for any repair which will be carried out on acceptance of our quotation. The benefits conferred by this warranty are in addition to all other rights and remedies in respect of the product, which the consumer has under the trade practices act and other state or territory laws in Australia and New Zealand.

Our goods come with guarantees that cannot be excluded under Australian and New Zealand Consumer Law. You are entitled to a replacement or refund for a major failure and for compensation for any other reasonably foreseeable loss or damage. You are also entitled to have the goods repaired or replaced if the goods fail to be of acceptable quality and the failure does not amount to a major failure.

*Please note the accessories are not covered under warranty.

BEFORE YOU SEND IN YOUR PRODUCT FOR SERVICE

Before sending in your product for service, please take a few minutes to do the following:

- In your instruction manual, read the troubleshooting section that describes common errors, their cause and remedies. Product instruction manuals can be downloaded online.
- Contact Welcare customer service. Our staff are trained to assist you with most issues you may have experienced, without the need to send your product in for service.

PLEASE CALL OUR TOLL FREE NUMBER:

IN AUSTRALIA:

Free call: 1800 807 464

IN NEW ZEALAND:

Free call: 0800 523 583

SENDING IN YOUR PRODUCT FOR SERVICE

1. Should repair be needed within the warranty period, enclose the cut-off section of the warranty form and your proof of purchase receipt. Please ensure all relevant details are completed before sending your product in for service. Please ensure your contact details are still current and include a brief description of the problem you are experiencing together with your purchase receipt.
2. Include the product with all product components in your package. This is extremely important, so our repair technicians can make the correct diagnosis with any problems.
3. Please return the product and warranty form at your cost to:

IN AUSTRALIA

J A DAVEY PTY LTD
Welcare Repairs
PO Box 84
Port Melbourne
Victoria, Australia 3207

IN NEW ZEALAND

BV Medical
Welcare Repairs
Unit 7, 110 Mays Road
Onehunga
Auckland, New Zealand 1061

Warranty Form

PLEASE RETAIN THE WARRANTY INFORMATION.
RETURN THIS PORTION ONLY WHEN YOU RETURN YOUR PRODUCT FOR REPAIR UNDER WARRANTY.

NAME:

ADDRESS:

POSTCODE:

DAYTIME PHONE:

EMAIL:

MODEL:

DATE OF PURCHASE:

/

/

PLEASE ATTACH PROOF OF PURCHASE

RETAILER'S NAME:

RETAILER'S ADDRESS:

POSTCODE:







BRIEF DESCRIPTION OF PROBLEM YOU ARE EXPERIENCING:

WARRANTY IS VOID UNLESS THE ABOVE INFORMATION IS COMPLETED
AND CORRECT.





Technical Data

Product Name	Welcare PureAir Household Air Purifier
Model Number	WPA300
Power	55W
Input	220-240V
Frequency	50Hz
Coverage Area	40~50m ²
CADR	310m ³ /h
Purification System	<p>6 Stage Air Purification System</p> <ol style="list-style-type: none"> 1. Pre-Filter 2. Efficient HEPA (H13) Filter 3. Activated Carbon Filter 4. Photocatalyst Filter 5. Anion 6. 2 pcs UV Lights
Noise Level	60dB(A)
Operating Conditions	<p> Temperature: 0°C to 40°C</p> <p> Humidity: ≤70% RH (non-condensing)</p> <p> Atmospheric Pressure: 860hPa-1060hPa</p>
Storage/ Transport Conditions	<p> Temperature: -10°C to 55 °C</p> <p> Humidity: ≤90% RH (non-condensing)</p> <p> Atmospheric Pressure: 860hPa-1060hPa</p>
Dimensions	402x185x624mm (main body only, out of packaging)
Weight	Gross 8.7kg (main body)
Materials	ABS + PP
Contents	Air purifier (including 6 pcs filter inside), user manual and warranty information



WELCARE

PUREAIR

**Should you require any further information
please do not hesitate to contact us.**

IN AUSTRALIA:

J A DAVEY PTY LTD

Telephone: 1800 807 464

Website: www.welcare.com.au

IN NEW ZEALAND:

J A DAVEY LTD

C/- Healthcare Logistics

Telephone: 0800 523 583

Website: www.jadavey.co.nz

Disposal

At the end of its life, please treat this product as electronic waste and dispose of responsibly according to current local regulations.



Made in China

V011/22