

# WELCARE

## PUREAIR

MODEL: WPA200



## ULTRAVIOLET AIR PURIFIER

WITH HEPA 13 FILTRATION

**Instruction Manual & Warranty Information**



Read Instructions Carefully Before Use

# WELCARE

## PUREAIR

**Thank you for purchasing this Welcare PureAir Ultraviolet Air Purifier with HEPA (H13) filtration**

Model: WPA200



**Please keep this instruction manual in a safe place where it is readily available.**

**Note:** *The illustrations in this manual may differ slightly from the product itself.*

# Contents

Important Safety Information . . . . .	4
Features . . . . .	5
Box Contents . . . . .	5
Welcare PureAir Ultraviolet Air Purifier Components . . . . .	6
Welcare PureAir Ultraviolet Air Purifier Display . . . . .	7
Before Using the Air Purifier. . . . .	7
Replacing the HEPA (H13) Filter . . . . .	8
Aromatherapy Function . . . . .	9
Replacement Accessories . . . . .	9
Using the Air Purifier . . . . .	10
Cleaning and Maintenance . . . . .	10
Storage . . . . .	11
Troubleshooting . . . . .	11
Warranty Information . . . . .	12
Warranty Form . . . . .	13
Technical Data . . . . .	15
Disposal . . . . .	16

# Important Safety Information



Read this section thoroughly before using the product.

Please ensure you observe the safety instructions to avoid accidents, injury and damage.

## Intended purpose

The **Welcare PureAir Ultraviolet Air Purifier with HEPA (H13) filtration** removes contaminants from the air in a room to improve indoor air quality. Indoor air pollution comes mainly from pollen, dust, harmful gasses including smoke, body odour, mold spores, bacteria, viruses and other substances which can be a serious problem. Clean, pure air is important to a person's health and wellbeing.

This product is **NOT** a therapeutic device.

This product is **NOT** intended for use by persons (including children) with limited physical, sensory or mental abilities or lacking experience and/or knowledge, unless they are supervised by a person responsible for their safety or have received and understand the instructions/safety warnings for use of the product from this person in advance.

## Safety Warnings

- Keep the product and its components out of reach of children.
- Dispose of any plastic packaging. Keep away from babies and children to avoid suffocation.
- **DO NOT** let children play with the product.
- Use only with the supplied AC adaptor.

## Warnings

- **DO NOT** drop or put heavy objects on the product.
- **DO NOT** allow the product to come in to contact with any sharp objects, as this could cause damage to the product.
- **DO NOT** allow the product to come in to contact with water, as this may cause electric shock.
- **DO NOT** cover the AC adapter as it may cause fire or electric shock.
- **DO NOT** expose to temperatures over 55°C.
- **DO NOT** cover the Air Purifier air inlet and outlet.
- Keep the Air Purifier unobstructed.
- If the AC adapter is damaged, contact the manufacturer for replacement.
- Disconnect from the power source before cleaning.
- Clean the product with a damp soft cloth and mild detergent if required.  
**DO NOT** use any harsh chemical cleaning agents. Dry with a soft cloth.

## Important Safety Information - *continued*

---

- **DO NOT** use liquids to clean Air Purifier such as water, detergents, or flammable solvents.
- **DO NOT** wash the HEPA (H13) filter with water, as it will lose the filtering function.
- The device is **ONLY** to be used with the supplied AC adapter.
- The UV-C LED is a delicate component of the device. Take care when cleaning to avoid damage.
- Maintain responsible use of essential oils.

## Features

- Ultraviolet/deep UV-C LED light kills 99.95% virus including COVID-19\*
- 360-degree air inlet with HEPA (H13) filtration
- Filters dust, pollen, smoke and bacteria<sup>†</sup>
- Reduces odours
- Suitable for desktops and small rooms up to 12m<sup>2</sup>
- Adjustable fan speed - 3 levels (low-mid-high)
- Timing function 1hr - 2hr - 4hr - 8hr
- Touch panel display for easy operation
- Sleep mode
- Filter replacement reminder display
- Child lock
- Low-noise operation
- Aromatherapy function
- Lightweight

## Box Contents

- 1 x Air Purifier (HEPA (H13) Air Purification system inside), includes pre-filter, HEPA (H13) filter plus ultraviolet deep UV-C light and 1 pair of aromatherapy sponges.
- 1x AC Adaptor
- 1 x Instruction Manual & Warranty Information

\* *Tested SARS-CoV-2 inactivation rate reaches 99.95% or more within 30 seconds.*

<sup>†</sup> Visit [welcare.com.au](http://welcare.com.au) for further details.



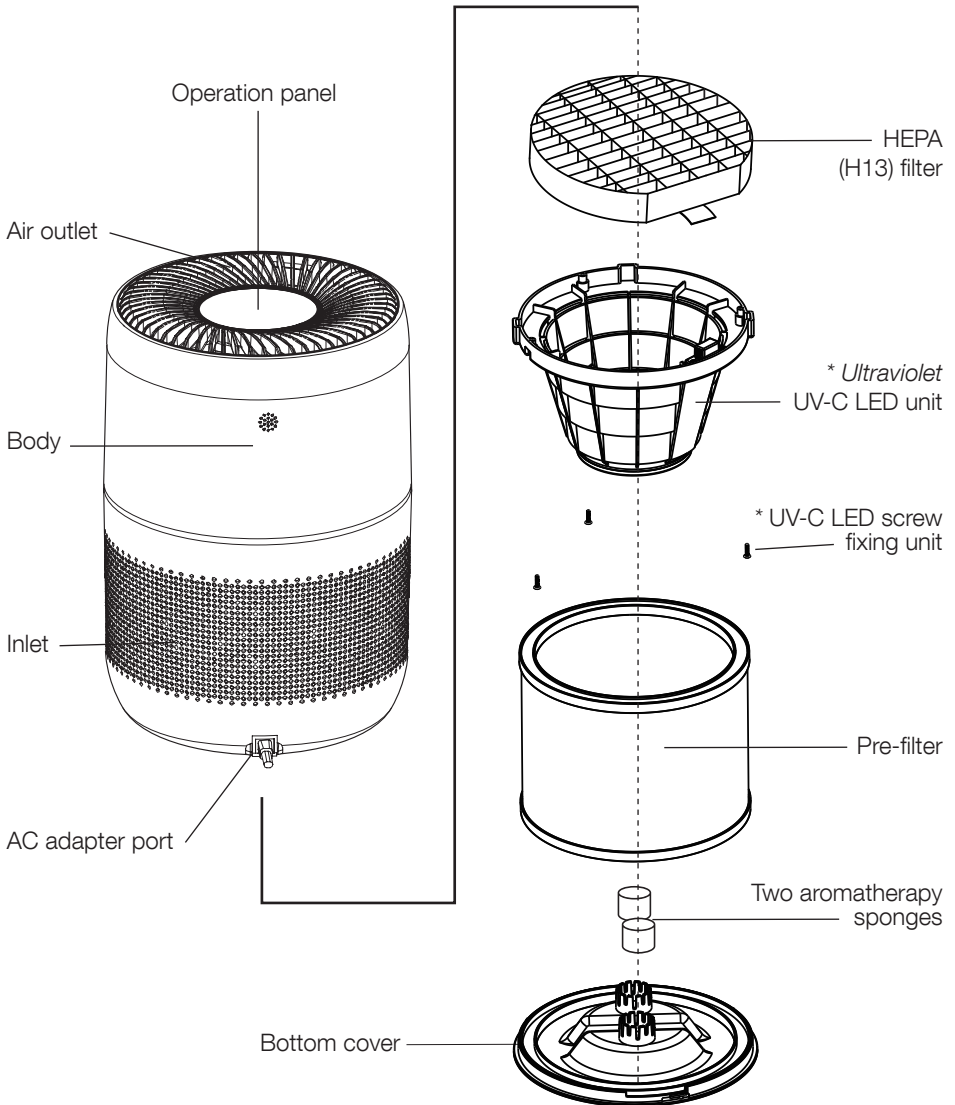

# Welcare PureAir Ultraviolet Air Purifier Components

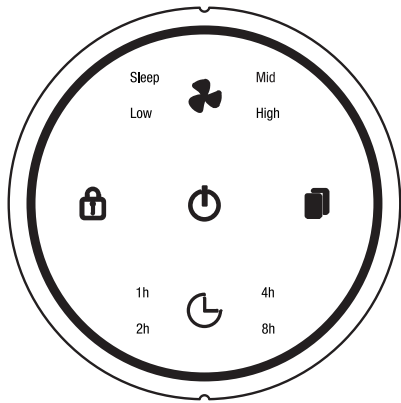

\* UV-C LED can be used safely and will not produce Ozone.

# Welcare PureAir Ultraviolet Air Purifier Display



-  Power On/Off
-  Fan speed function  
Low → Mid → High → Sleep
-  Child lock
-  Replacement filter indicator
-  Timer function  
1hr → 2hr → 4hr → 8hr

## Before Using the Air Purifier

- Carefully remove all packaging materials and keep the enclosed documents in a safe place.
- **Keep the packaging, product, and its components out of reach of children.**
- Check the product is intact. **DO NOT** use if broken.
- Remove the protective film from the screen.
- Ensure AC adaptor is fully inserted into the base.
- Plug the product into the power source.

**If any abnormalities are detected, please contact our service centre:**

**In Australia - 1800 807 464**

**In New Zealand - 0800 523 583**

# Replacing the HEPA (H13) Filter

- Turn off the power button then disconnect the AC adaptor from the wall socket.
- Disconnect the main body from the AC adaptor.
- The replacement HEPA (H13) filter must be removed from the plastic bag.
- Remove the bottom cover by holding the bottom cover rotation handle then turn the bottom cover anti-clockwise to unlock (*figure 1*).
- Remove the pre-filter.
- Remove the 3 screws with a screwdriver (*figure 2*)  
(it is recommended the screwdriver handle be at least 10cm long with a magnetic tip).
- Remove the UV-C LED unit (*figure 3*).

figure 1.

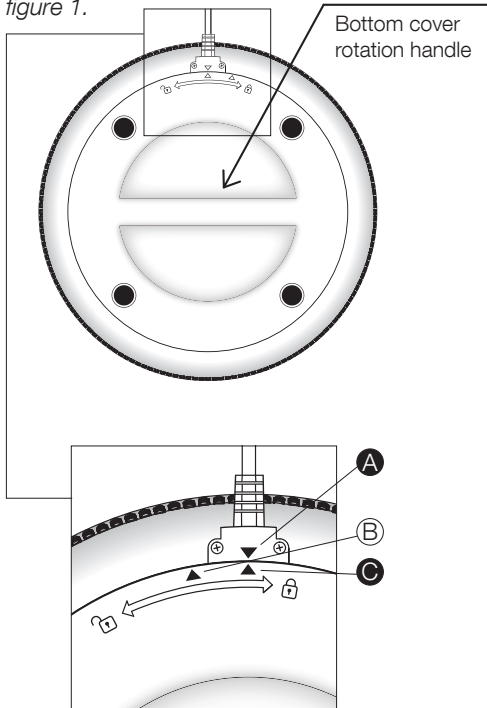

Turn the bottom cover anti-clockwise to align arrows **A** & **C** to **unlock** and remove the bottom cover.

figure 2.

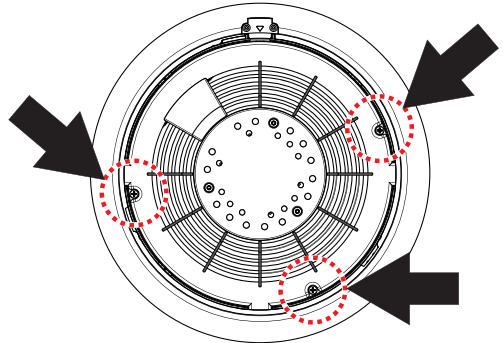
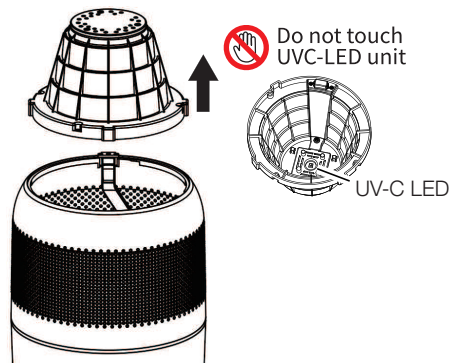

figure 3.





## Replacing the HEPA (H13) Filter - *continued*

figure 4.

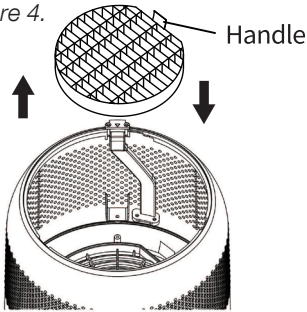

- Place the HEPA (H13) filter with the tab facing upwards.
- Install removed parts, including the 3 screws
- Replace the bottom cover and reconnect the AC adaptor to the main body and wall socket.
- Press the filter replacement button  for approximately 5 seconds.

## Aromatherapy Function

- Remove the bottom cover.  
(refer to figure 1, page 8)
- There are two sponges attached to the inside of the bottom cover (as shown in figure 5).
- Add several drops of your preferred essential oil onto each of the sponges.
- Replace the bottom cover.
- When the Air Purifier is operating, the scent will slowly emit with the breeze.

figure 5.

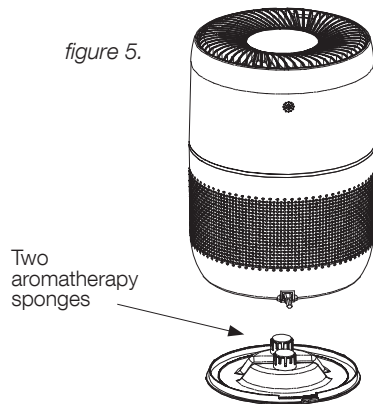

## Replacement Accessories

Replacement accessories can be purchased online or by contacting us directly:

**Australia:** 1800 807 464      [www.welcare.com.au](http://www.welcare.com.au)

**New Zealand:** 0800 523 583      [www.jadavey.co.nz](http://www.jadavey.co.nz)

Part Code	Part Name
WPA200-1	HEPA (H13) Filter (FIL-MY7)
WPA100-2	Aromatherapy Sponges (AP1207SP-AS)

## Using the Air Purifier



**Standby:** Insert the AC adaptor into the port on the main body of the Air Purifier, then insert the plug into the wall socket. The buzzer will sound, and all the indicators will light up. After three seconds, the Air Purifier will be in standby mode. The “power button” indicator lights up in **RED**. **Please note:** no other icons will light up.



### **Power On/Off:**

Tap the top power icon to switch the power on. Tap again to switch the power off. The default fan speed is Mid, and the child lock will be off.



**Fan Speed Function:** Tap the fan speed adjustment icon to choose fan speed - Mid → High → Sleep → Low.



**Sleep Mode:** When the sleep function is activated, the power, fan speed and sleep icons will illuminate at half brightness. All other icons will turn off.



**Child Lock:** Press the icon for three seconds to switch the child lock ON/OFF.

- If the icon light is continuous, the child lock function is turned OFF.
- If the icon light is flashing, the child lock function is turned ON.



**Replace the Filter:** When the filter has been used for approx. 6,000 hours, the replacement filter indicator light will flash, and the buzzer will beep. After replacing with a new filter, hold the filter reset icon for five seconds until the light fully illuminates and no longer flashes. At the same time, the buzzer will stop sounding. This button can also be used to turn the air quality indicator lights on and off (by pressing once).



**Timer Function:** Touch the timer icon, adjust the countdown shutdown time 1hr → 2hr → 4hr → 8hr. The sequence will then loop.

**Note:** If no timer is set, the Air Purifier will continuously operate until it is manually switched off.

## Cleaning and Maintenance

**The pre-filter should be cleaned every 3 months to maintain optimum performance**

- When cleaning, always turn off the power and disconnect from the power source.
- Clean the main body of the Air Purifier with a damp soft cloth and mild detergent if required. Dry with a soft cloth.
- **DO NOT** use any harsh chemical cleaning agents.
- Remove the pre-filter, use a vacuum cleaner to absorb the dust around the circumference of the pre-filter.
- **ONLY** the pre-filter can be cleaned with water.
- The HEPA (H13) filter and UV-C LED light **CANNOT** be cleaned.

## Storage

- Wipe away any dirt and dust from the product.
- Store in a safe cool dry place, away from children as per Safety Warnings.
- **DO NOT** place any heavy objects on the product.

## Troubleshooting

Problem	Possible Cause	Solution
The Air Purifier does not turn on.	The AC adaptor is not connected to the main body of the Air Purifier.	Insert the AC adaptor into the main body of the Air Purifier.
	The AC adaptor is not plugged in to the wall socket.	Plug the AC adaptor into the wall socket.
	The AC adaptor is faulty.	Discontinue use until a replacement AC adaptor is received.
The Air Purifier turns off by itself.	The timing function is in use.	Press the power button to restart the Air Purifier.
Poor performance.	The area around the Air Purifier is not clear of objects.	Remove any objects around the Air Purifier.
	The pre-filter needs cleaning.	Clean the pre-filter as per the instructions.
	The HEPA (H13) filter needs replacing.	Replace the HEPA (H13) filter as per the instructions.
The Air Purifier is beeping.	The HEPA (H13) filter needs replacing.	Replace the filter as per instructions.
The Air Purifier will not turn off.	The child lock function is on.	Turn off the child lock.

If the problem is not solved by the troubleshooting guide or you have any queries, please contact our service centre:

**In Australia** - 1800 807 464

**In New Zealand** - 0800 523 583

**DO NOT** attempt to open or repair the product yourself.

# Warranty Information

## PRODUCT WARRANTY

Please register your warranty information at: **AUS - [www.jadavey.com.au/warranty/](http://www.jadavey.com.au/warranty/)**  
**NZ – [www.jadavey.co.nz](http://www.jadavey.co.nz)**

This **Welcare PureAir** product is warranted to be free of manufacturing defects for 1 year from the date of purchase\*. This warranty is void if the product is modified or altered, is subject to misuse or abuse, damaged in transit or lack of responsible care, is dropped, if damage occurs by reason of failure to follow the written instruction booklet, or if product repairs are carried out without authority from J A Davey Pty Ltd.

We will repair, or at our option replace free of charge, any parts necessary to correct material or workmanship, or replace the entire product and return to you during the period of the warranty. Otherwise, we will quote for any repair which will be carried out on acceptance of our quotation. The benefits conferred by this warranty are in addition to all other rights and remedies in respect of the product, which the consumer has under the trade practices act and other state or territory laws in Australia and New Zealand.

Our goods come with guarantees that cannot be excluded under Australian and New Zealand Consumer Law. You are entitled to a replacement or refund for a major failure and for compensation for any other reasonably foreseeable loss or damage. You are also entitled to have the goods repaired or replaced if the goods fail to be of acceptable quality and the failure does not amount to a major failure.

\*Please note the accessories are not covered under warranty.

### BEFORE YOU SEND IN YOUR UNIT FOR SERVICE

Before sending in your product for service, please take a few minutes to do the following:

- In your instruction manual, read the troubleshooting section that describes common errors, their cause and remedies. Product instruction manuals can be downloaded online.
- Contact Welcare customer service. Our staff are trained to assist you with most issues you may have experienced, without the need to send your product in for service.

### PLEASE CALL OUR TOLL FREE NUMBER:

#### IN AUSTRALIA:

Free call: 1800 807 464

#### IN NEW ZEALAND:

Free call: 0800 523 583

### SENDING IN YOUR UNIT FOR SERVICE

1. Should repair be needed within the warranty period, enclose the cut-off section of the warranty form and your proof of purchase receipt. Please ensure all relevant details are completed before sending your unit in for service. Please ensure your contact details are still current and include a brief description of the problem you are experiencing together with your purchase receipt.
2. Include the unit with all product components in your package. This is extremely important, so our repair technicians can make the correct diagnosis with any problems.
3. Please return the product and warranty form at your cost to:

#### IN AUSTRALIA

J A DAVEY PTY LTD  
Welcare Repairs  
PO Box 84  
Port Melbourne  
Victoria, Australia 3207

#### IN NEW ZEALAND

BV Medical  
Welcare Repairs  
Unit 7, 110 Mays Road  
Onehunga  
Auckland, New Zealand 1061

# Warranty Form

PLEASE RETAIN THE WARRANTY INFORMATION.  
RETURN THIS PORTION ONLY WHEN YOU RETURN YOUR PRODUCT FOR REPAIR UNDER WARRANTY.

NAME:

---

ADDRESS:

---

POSTCODE:

DAYTIME PHONE:

---

EMAIL:

---

MODEL:

DATE OF PURCHASE:

/

/

---

PLEASE ATTACH PROOF OF PURCHASE

RETAILER'S NAME:

---

RETAILER'S ADDRESS:

---

POSTCODE:

---

BRIEF DESCRIPTION OF PROBLEM YOU ARE EXPERIENCING:

---

---

---







---

WARRANTY IS VOID UNLESS THE ABOVE INFORMATION IS COMPLETED  
AND CORRECT.





# Technical Data

<b>Product Name</b>	Welcare PureAir Ultraviolet Air Purifier with HEPA (H13) filtration
<b>Model Number</b>	WPA200
<b>Power</b>	14W
<b>Input</b>	220-240V ~ 50Hz 0.7A
<b>Output</b>	24.0V = 1.0A
<b>Coverage Area</b>	12m <sup>2</sup>
<b>CADR</b>	103m <sup>3</sup> /h
<b>Purification System</b>	3 Stage filtration: Pre-filter, HEPA (H13) filter, UV-C LED light
<b>Noise</b>	56dB(A)
<b>Operating Conditions</b>	 Temperature: 0°C to 40°C  Humidity: ≤70% RH (non-condensing)  Atmospheric Pressure: 860hPa-1060hPa
<b>Storage/ Transport Conditions</b>	 Temperature: -10°C to 55°C  Humidity: ≤90% RH (non-condensing)  Atmospheric Pressure: 860hPa-1060hPa
<b>Dimensions</b>	225x225x310mm (out of packaging)
<b>Weight</b>	Approx. 2.2Kg (main body)
<b>Materials</b>	ABS + PP
<b>Contents</b>	1x Air Purifier with pre-filter, HEPA (H13) filter and UV-C LED light plus 1 pair of aromatherapy sponges. 1x AC Adaptor 1 x Instruction Manual & Warranty Information





**Should you require any further information  
please do not hesitate to contact us.**

**IN AUSTRALIA:**

J A DAVEY PTY LTD  
Telephone: 1800 807 464  
Website: [www.welcare.com.au](http://www.welcare.com.au)

**IN NEW ZEALAND:**

J A DAVEY LTD  
C/- Healthcare Logistics  
Telephone: 0800 523 583  
Website: [www.jadavey.co.nz](http://www.jadavey.co.nz)

## Disposal

At the end of its life, please treat this product as electronic waste and dispose of responsibly according to current local regulations.



Made in China

V09/22