

# WELCARE

## PUREAIR

MODEL: WPA100



## DESKTOP AIR PURIFIER

### Instruction Manual & Warranty Information



Read Instructions Carefully Before Use

# WELCARE

## PUREAIR

**Thank you for purchasing this Welcare PureAir Desktop Air Purifier**

Model: WPA100



**Please keep this instruction manual in a safe place where it is readily available.**

**Note:** *The illustrations in this manual may differ slightly from the product itself.*

# Contents

Important Safety Information . . . . .	4
Features . . . . .	5
Box Contents . . . . .	6
Welcare PureAir Desktop Air Purifier Components . . . . .	6
Welcare PureAir Desktop Air Purifier Display . . . . .	7
Before Using the Air Purifier. . . . .	7
Air Purifier Filter Installation . . . . .	8
Aromatherapy Function . . . . .	9
Replacement Accessories . . . . .	9
Using the Air Purifier . . . . .	10
Cleaning and Maintenance . . . . .	10
Storage. . . . .	11
Troubleshooting . . . . .	11
Warranty Information . . . . .	12
Warranty Form . . . . .	13
Technical Data . . . . .	15
Disposal . . . . .	16

# Important Safety Information



Read this section thoroughly before using the product.

Please ensure you observe the safety instructions to avoid accidents, injury and damage.

## Intended purpose

The Welcare PureAir Desktop Air Purifier removes contaminants from the air in a room to improve indoor air quality. Indoor air pollution comes mainly from pollen, dust, harmful gasses including smoke, body odour and other substances which can be a serious problem, causing dizziness, drowsiness, congestion, and nausea. Clean pure air is important to a person's health and wellbeing.

This product is **NOT** a therapeutic device.

This product is not intended for use by persons (including children) with limited physical, sensory or mental abilities or lacking experience and/or knowledge, unless they are supervised by a person responsible for their safety or have received and understand the instructions/safety warnings for use of the product from this person in advance.

## Safety Warnings

- Keep the product and its components out of reach of children.
- Keep children away from the packaging material.
- Dispose of the plastic bag. Keep away from babies and children to avoid suffocation.
- **DO NOT** let children play with the product.

## Warnings

- **DO NOT** drop or put heavy objects on the product.
- **DO NOT** allow the product to come into contact with any sharp objects, as this could cause damage to the product.
- **DO NOT** attempt to open or disassemble the product.
- **DO NOT** expose to temperatures over 55°C.
- Only use in a 220-240V wall outlet to avoid overheating.
- If the supplied power cord is damaged, it must be replaced by the manufacturer, its service agent, or a similarly qualified person to avoid a hazard.
- Clean the product with a damp soft cloth and mild detergent if required. **DO NOT** use any harsh chemical cleaning agents. Dry with a soft cloth.
- Never use liquids such as water, detergents, or flammable solvents to clean the product.





## Important Safety Information - *continued*

- When cleaning the product, please disconnect from the power source.
- This product uses precision components. Please position the product on an even, steady surface to prevent it from falling or being damaged.
- Keep the space surrounding the product unobstructed. **DO NOT** cover the air inlet and outlet.
- Maintain responsible use of essential oil.

## Features

- 360-degree HEPA (H13) filtration
- Suitable for desktops and small rooms up to 12.36m<sup>2</sup>
- Filter's dust, pollen, smoke, germs, and bacteria
- Removes odours
- Adjustable fan speed - 4 Levels (one button)
- Timing function 1hr - 2hr - 4hr - 8hr
- Touch panel display for easy operation Sleep mode
- Filter replacement reminder display
- Child lock
- Low-noise operation
- Aromatherapy function
- Lightweight
- Dust sensor & Air quality indicator (4 colours):  
**Blue**-Perfect, **Green**-Good, **Purple**-Normal, **Red**-Bad

### Air quality indicator

	Blue	(PM2.5=0~50)	PERFECT
	Green	(PM2.5=50~100)	GOOD
	Purple	(PM2.5=100~150)	NORMAL
	Red	(PM2.5=>150)	BAD

*PM2.5 = particles which have a diameter of less than 2.5 microns*

## Box Contents



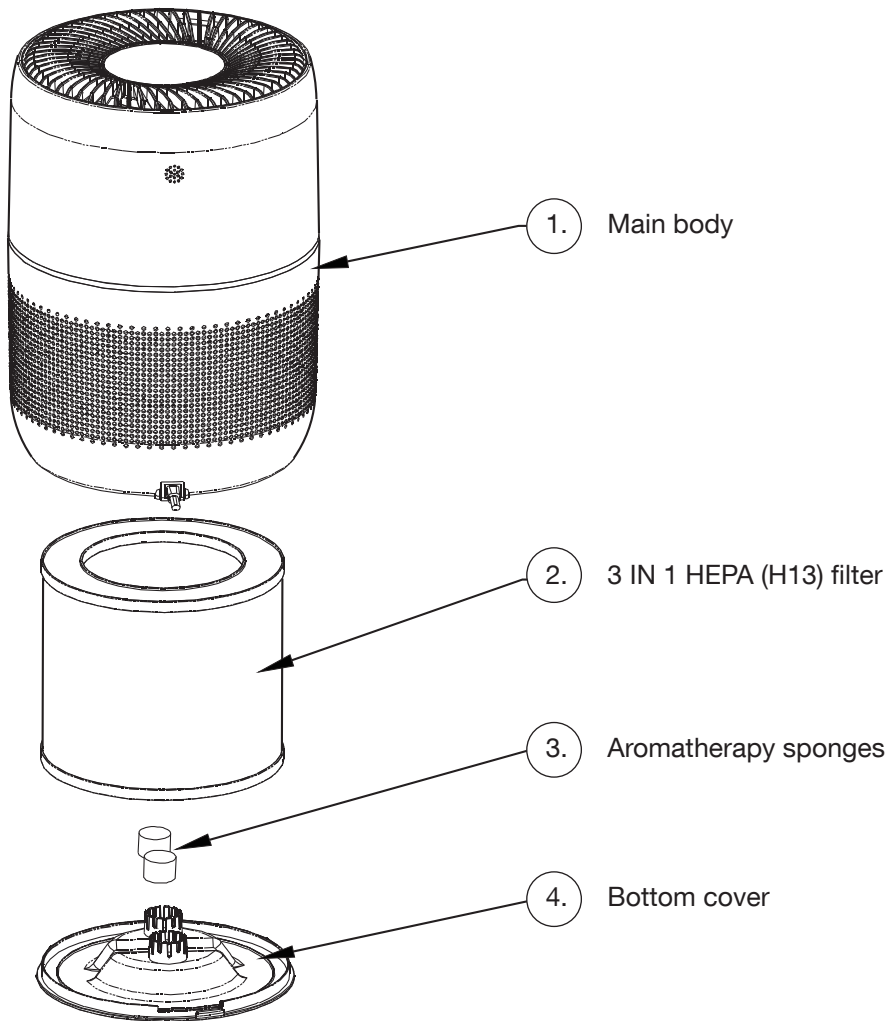

- 1 x Air purifier (including 1 pcs HEPA (H13) filter and 1 pair of aromatherapy sponges inside)
- 1 x Instruction Manual & Warranty Information

## Welcare PureAir Desktop Air Purifier Components

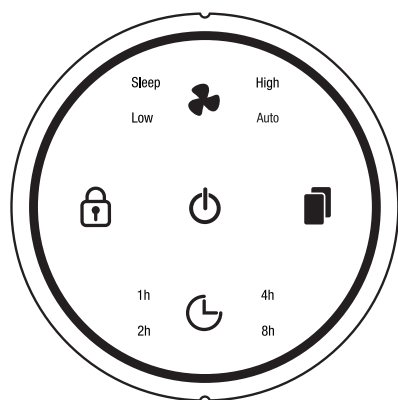

# Welcare PureAir Desktop Air Purifier Display



-  Power On/Off
-  Fan speed function  
Low → High → Auto → Sleep
-  Child lock
-  Replacement filter indicator
-  Timer function  
1hr → 2hr → 4hr → 8hr

## Before Using the Air Purifier

- Before turning on the product for the first time, remove the filter bag.
- Carefully remove all packaging materials and keep the enclosed documents in a safe place.
- **Keep the packaging, product, and its components out of reach of children.**
- Check the product is intact. **DO NOT** use if broken.
- Remove the protective film from the screen.
- Plug the product into the power source.

**If any abnormalities are detected, please contact our service centre:**

**In Australia - 1800 807 464**

**In New Zealand - 0800 523 583**

# Air Purifier Filter Installation

1. Hold the bottom cover rotation handle. (figure 1.)
2. Turn the bottom cover anti-clockwise to unlock. (figure 1a.)
3. Remove the cover.
4. Remove the filter as shown. (figure 2.)
5. Remove the plastic bag and put the filter back into the unit.
  - a. Dispose of the plastic bag. **Keep away from babies and children to avoid suffocation.**
6. Place the filter back into the unit.
7. Place the bottom cover back in the unit.
8. Rotate the bottom cover clockwise to lock into place. (figure 1b.)

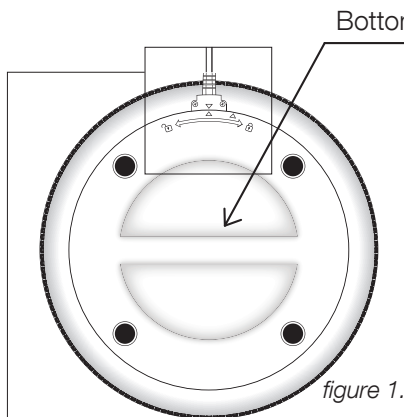

figure 1.

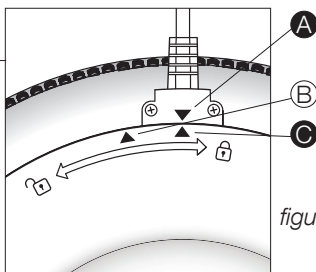

figure 1a.

Turn the bottom cover anti-clockwise to align arrows **A & C** to **unlock** and remove the bottom cover.

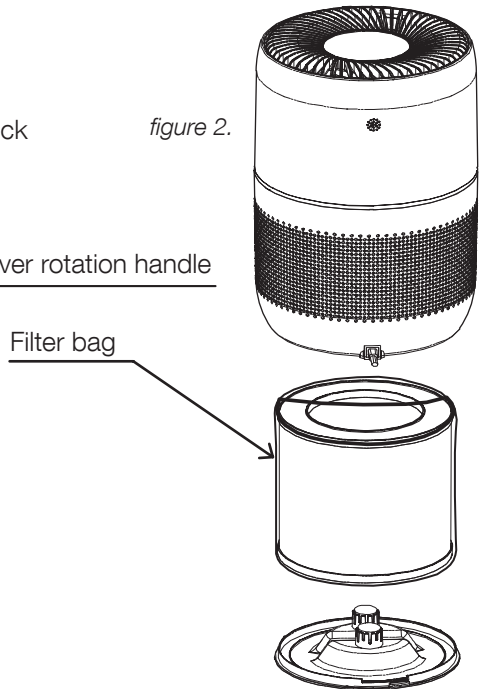

figure 2.

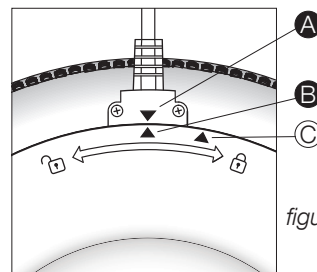

figure 1b.

Turn the bottom cover clockwise to align arrows **A & B** to **lock** the bottom cover in place.

8.

Welcare PureAir Desktop Air Purifier



## Aromatherapy Function

- Remove the bottom cover. (figure 1a.)
- There are two sponges attached to the inside of the bottom cover of the machine (as shown by the arrow in figure 3).
- Add several drops of your preferred essential oil onto each of the sponges.
- When the air purifier is operating, the scent will slowly emit with the breeze.

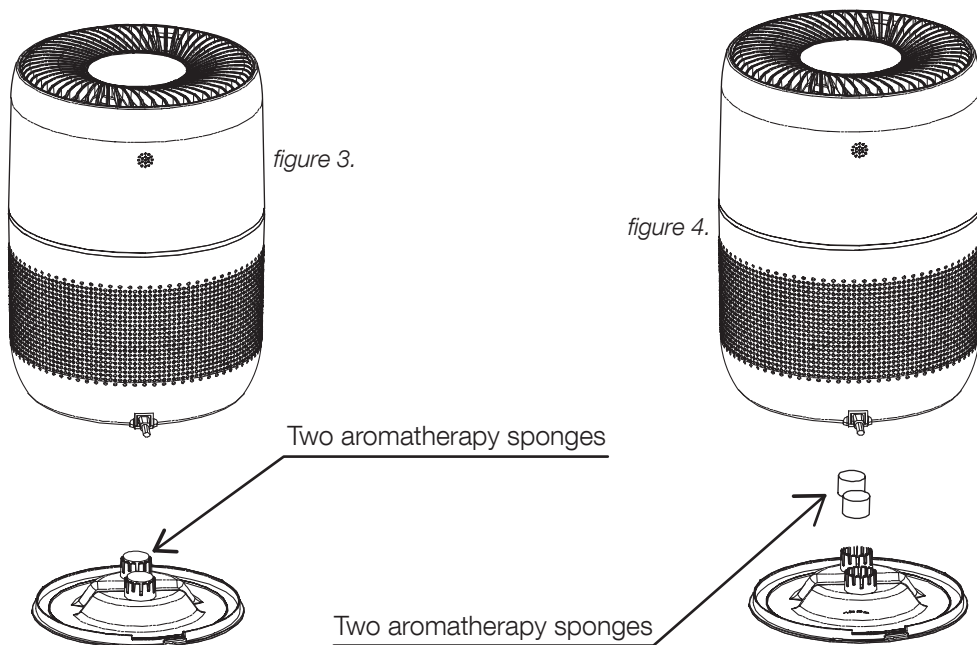

## Replacement Accessories

Replacement accessories can be purchased online or by contacting us directly:

**Australia:** 1800 807 464      [www.welcare.com.au](http://www.welcare.com.au)

**New Zealand:** 0800 523 583      [www.jadavey.co.nz](http://www.jadavey.co.nz)

Part Code	Part Name
WPA100-1	3 IN 1 Filter (FIL1207)
WPA100-2	Aromatherapy Sponges (AP1207SP-AS)

## Using the Air Purifier



### Standby:

Insert the plug of the air purifier into a power source. The buzzer will sound, and all the indicators will light up. After three seconds, the air purifier will be in standby mode. The “power button” indicator lights up in **RED**.

**Please note:** no other icons will light up.



### Power On/Off:

Tap the top power icon to switch the power on. Tap again to switch the power off. The default fan speed is low, and the child lock is off.



### Fan Speed Function:

Tap the fan speed adjustment icon to choose fan speed - Low → High → Auto → Sleep



### Sleep Mode:

When the sleep function is activated, the indicator lights will turn off except for the sleep icon which will remain fully illuminated. The power and fan speed icons will remain illuminated at half brightness.



### Child Lock:

Press the icon for three seconds to switch the child lock on/off.

- If the icon light is continuous, the child lock function is turned OFF.
- If the icon light is flashing, the child lock function is turned ON.



### Replace the Filter:

When the filter has been used for approx. 2,000 hours, the replacement filter indicator light will flash, and the buzzer will beep.

After replacing with a new filter, hold the filter reset icon for three seconds until the light fully illuminates and no longer flashes. At the same time, the buzzer will stop sounding. This button can also be used to turn the air quality indicator lights on and off (by pressing once).



### Timer Function:

Touch the timer icon, adjust the countdown shutdown time 1hr → 2hr → 4hr → 8hr. The sequence will then loop.

**Note:** If no timer is set, the air purifier will continuously operate until it is manually switched off.

## Cleaning and Maintenance

- When cleaning, always turn off the power and disconnect from the power source.
- Clean the product with a damp soft cloth and mild detergent if required.
- Dry with a soft cloth.

## Storage

- **DO NOT** use any harsh chemical cleaning agents.
- Wipe away any dirt and dust from the product.
- Store in a safe cool dry place, away from children as per Safety Warnings.
- **DO NOT** place any heavy objects on the product.

## Troubleshooting

Problem	Possible Cause	Solution
The Air Purifier does not turn on.	The machine plug and power plug are not inserted into the power source correctly.	Insert into the power source correctly.
The fan does not work.	The product inlet or outlet may be blocked.	Remove any objects away from the inlet/outlet area.
	Plastic packaging may not have been removed.	Remove any plastic packaging from the filter.
Performance is poor or is not performing at its optimal purification performance.	The area around the product is not clear of objects.	Remove any objects around the unit.
	Filters may need replacing.	Replace the filter as per instructions.
The product beeps.	Filters requiring replacement.	Replace the filter as per instructions.
Air quality indicator is always red.	There is a continued source of pollution near the product such as smoke.	Remove source of pollution, then the air quality indicator will change colour as air quality improves.

If the problem is not solved by the troubleshooting guide or you have any queries, please contact our service centre:

**In Australia** - 1800 807 464

**In New Zealand** - 0800 523 583

**DO NOT** attempt to open or repair the product yourself.

# Warranty Information

## PRODUCT WARRANTY

Please register your warranty information at: **AUS - [www.welcare.com.au](http://www.welcare.com.au)**  
**NZ - [www.jadavey.co.nz](http://www.jadavey.co.nz)**

This Welcare PureAir product is warranted to be free of manufacturing defects for 1 year from the date of purchase\*. This warranty is void if the product is modified or altered, is subject to misuse or abuse, damaged in transit or lack of responsible care, is dropped, if damage occurs by reason of failure to follow the written instruction booklet, or if product repairs are carried out without authority from J.A. Davey Pty Ltd.

We will repair, or at our option replace free of charge, any parts necessary to correct material or workmanship, or replace the entire product and return to you during the period of the warranty. Otherwise, we will quote for any repair which will be carried out on acceptance of our quotation. The benefits conferred by this warranty are in addition to all other rights and remedies in respect of the product, which the consumer has under the trade practices act and other state or territory laws in Australia and New Zealand.

Our goods come with guarantees that cannot be excluded under Australian and New Zealand Consumer Law. You are entitled to a replacement or refund for a major failure and for compensation for any other reasonably foreseeable loss or damage. You are also entitled to have the goods repaired or replaced if the goods fail to be of acceptable quality and the failure does not amount to a major failure.

\*Please note the accessories are not covered under warranty.

### BEFORE YOU SEND IN YOUR UNIT FOR SERVICE

Before sending in your product for service, please take a few minutes to do the following:

- In your instruction manual, read the troubleshooting section that describes common errors, their cause and remedies. Product instruction manuals can be downloaded online.
- Contact Welcare customer service. Our staff are trained to assist you with most issues you may have experienced, without the need to send your product in for service.

### PLEASE CALL OUR TOLL FREE NUMBER:

#### IN AUSTRALIA:

Free call: 1800 807 464

#### IN NEW ZEALAND:

Free call: 0800 523 583

### SENDING IN YOUR UNIT FOR SERVICE

1. Should repair be needed within the warranty period, enclose the cut-off section of the warranty form and your proof of purchase receipt. Please ensure all relevant details are completed before sending your unit in for service. Please ensure your contact details are still current and include a brief description of the problem you are experiencing together with your purchase receipt.
2. Include the unit with all product components in your package. This is extremely important, so our repair technicians can make the correct diagnosis with any problems.
3. Please return the product and warranty form at your cost to:

#### IN AUSTRALIA

J A DAVEY PTY LTD  
Welcare Repairs  
PO Box 84  
Port Melbourne  
Victoria, Australia 3207

#### IN NEW ZEALAND

BV Medical  
Welcare Repairs  
Unit 7, 110 Mays Road  
Onehunga  
Auckland, New Zealand 1061

# Warranty Form

PLEASE RETAIN THE WARRANTY INFORMATION.  
RETURN THIS PORTION ONLY WHEN YOU RETURN YOUR PRODUCT FOR REPAIR UNDER WARRANTY.

NAME: \_\_\_\_\_

ADDRESS: \_\_\_\_\_

POSTCODE: \_\_\_\_\_ DAYTIME PHONE: \_\_\_\_\_

EMAIL: \_\_\_\_\_

MODEL: \_\_\_\_\_ DATE OF PURCHASE:     /     /

PLEASE ATTACH PROOF OF PURCHASE

RETAILER'S NAME: \_\_\_\_\_

RETAILER'S ADDRESS: \_\_\_\_\_

POSTCODE: \_\_\_\_\_

BRIEF DESCRIPTION OF PROBLEM YOU ARE EXPERIENCING:

\_\_\_\_\_

\_\_\_\_\_

\_\_\_\_\_

\_\_\_\_\_







\_\_\_\_\_



WARRANTY IS VOID UNLESS THE ABOVE INFORMATION IS COMPLETED  
AND CORRECT.



## Technical Data

<b>Product Name</b>	Welcare PureAir Desktop Air Purifier
<b>Model Number</b>	WPA100
<b>Power</b>	30W
<b>Input</b>	AC220-240V/50HZ
<b>Coverage Area</b>	12.36m <sup>2</sup>
<b>CADR</b>	103m <sup>3</sup> /h
<b>Purification System</b>	3 IN 1 Filter - Pre-filter, HEPA filter (H13), Activated carbon filter
<b>Noise</b>	55dB(A)
<b>Operating Conditions</b>	 Temperature: 0°C to 40°C  Humidity: ≤70% RH (non-condensing)  Atmospheric Pressure: 860hPa-1060hPa
<b>Storage/ Transport Conditions</b>	 Temperature: -10°C to 55 °C  Humidity: ≤90% RH (non-condensing)  Atmospheric Pressure: 860hPa-1060hPa
<b>Dimensions</b>	225x225x310mm (out of packaging)
<b>Weight</b>	Approx. 2.5Kg (main body)
<b>Materials</b>	ABS + PP
<b>Contents</b>	Air purifier (including 1 pcs HEPA (H13) filter and 1 pair aromatherapy sponges inside), Instruction Manual & Warranty Information



# WELCARE

## PUREAIR

**Should you require any further information  
please do not hesitate to contact us.**

**IN AUSTRALIA:**

J A DAVEY PTY LTD

Telephone: 1800 807 464

Website: [www.welcare.com.au](http://www.welcare.com.au)

**IN NEW ZEALAND:**

J A DAVEY LTD

C/- Healthcare Logistics

Telephone: 0800 523 583

Website: [www.jadavey.co.nz](http://www.jadavey.co.nz)

## Disposal

At the end of its life, please treat this product as electronic waste and dispose of responsibly according to current local regulations.



Made in China

V02/22